

Pressure transducer model KX1, KXK, KXD, KXDHT, KXD (Exi)

Complete stainless steel thinfilm sensor without internal liquid filling
Accuracy 0,25 %, 0,5 % and 1 % F.S.

Features

- Rugged stainless steel construction
- High overpressure limits
- High shock and vibration stability
- Excellent long term stability
- Protection IP65, IP67 and IP68
- Explosion proof (intrinsically safe) for zone 1 and 2 acc. ATEX



Ranges

-1 ... 0 bar up to 0 ... 1400 bar
-30 in. Hg ... 0 psi up to 0 ... 20.000 psi

Technical specifications	KX1	KXK	KXD	KXDHT	KXD (Exi)
Measuring principle	Thinfilm				
Range [bar]	1 1,6 2,5 4 6 10 16 25 40 60 100 160 250 400 600 1000 1400				
Overpressure limit [bar]	6 6 6 10 14 20 40 70 100 138 200 304 525 640 900 1200 1680				
Pressure type	Gauge, vacuum and compound				
Process connection	G 1/4 B male according EN 837-1 1/4 NPT male according ANSI/ASME B1.20.1/EN 837-1 9/16-18 UNF-2B Aminco (high pressure) G 1/2 B male according EN 837-1 1/2 NPT male according ANSI/ASME B1.20.1 Others on request (for pressure limitations see order information)				
Material	Stainless steel 316Ti (1.4571) Stainless steel 1.4542/1.4548 (17-4PH) with polysilicon cell Stainless steel 304L (1.4306) Stainless steel 304 (1.4301)				
Process connection	Stainless steel 316Ti (1.4571)				
Sensor	Stainless steel 1.4542/1.4548 (17-4PH) with polysilicon cell				
Case	Stainless steel 304L (1.4306) Stainless steel 304 (1.4301)				
Power supply	12 ... 30 VDC	10 ... 30 VDC	12 ... 30 VDC		12 ... 26 VDC
Output signal	4 ... 20 mA, 2-wire	0 ... 10 VDC, 3-wire 0 ... 5 VDC, 3-wire 1 ... 5/6 VDC, 3-wire 0 ... 20 mA, 3-wire			4 ... 20 mA, 2-wire
Maximum loop resistance for 4 ... 20 mA	≤ (U _B - 9,5 V) / 0,02 A		≤ (U _B - 9 V) / 0,02 A		≤ (U _B - 11,2 V) / 0,02 A
Explosion proof (intrinsically safe)					EEx ib IIC T6 or T5 according to PTB 02 ATEX 2194 CE 0518 Ex II 2 GD
Isolation between case and electrical connection	> 1 MΩ at 50 VDC				
Isolation voltage	350 VAC				
Supply current	max. 5 mA for VDC output, 20 mA for 4 ... 20 mA output signal				
Accuracy according DIN 16 086 (terminal point)	0,5 % F.S. ¹⁾ 0,25 % F.S. ²⁾	1 % F.S. ¹⁾ 0,5 % F.S. ²⁾	0,5 % F.S. ¹⁾ 0,25 % F.S. ²⁾		
Repeatability	¹⁾ 1,0 % F.S. for the ranges 1 bar, 1,6 bar, 2,5 bar, 600 bar, 1000 bar and 1400 bar ²⁾ not for the ranges 1 bar, 1,6 bar, 2,5 bar, 600 bar, 1000 bar and 1400 bar				
Response time (10 ... 90 %)	≤ ±0,03 % F.S. ≤ 1 ms				
Permissible					
Operation temperature	-30 ... 85 °C			-30 ... 85 °C	For T5 and T6 (EEx ib) -20 ... 60 °C T6 -20 ... 75 °C T5
Medium temperature	-30 ... 100 °C			-30 ... 150 °C	-20 ... 60 °C T6 -20 ... 75 °C T5
Storage temperature	-40 ... 100 °C				
Compensated temperature	-20 ... 70 °C				
Temperature influence	±0,3 % / 10 K from 0 ... 50 °C (ref. 20 °C)				
Shock resistance	At 100 g / 20 ms ≤ 0,05 % F.S.				
Vibration	≤ 0,1 % F.S. for 0 ... 2000 Hz, 20 g in all directions according IEC 770				
Noise of output signal	≤ 0,02 % F.S.				
CE-mark/EMC	Emission according EN 50 081-1 (March 1993), immunity according EN 50 082-2 (March 1995)				
Electrical connection	4 PIN angle connector series M Cable connection Bendix 4 PIN, Amphenol 4 PIN	4 PIN angle connector according DIN EN 175301-803 Cable connection Field housing			
Protection according EN 60 529/IEC 529	IP65, IP67 for KX1 with Bendix 4 PIN, optional IP68				IP65 for dust with cable connection IP65 for gas with angle connector IP67 for gas with cable connection
Weight [kg]	0,1	0,2	0,25	0,4	0,25
Accessories, options	Diaphragm seals, valves				

All specifications are subject to change without notice.

G5.KXD/E Rev. H 01/06/2006 1. Änderung seit Rev. H

General dimensions [mm]

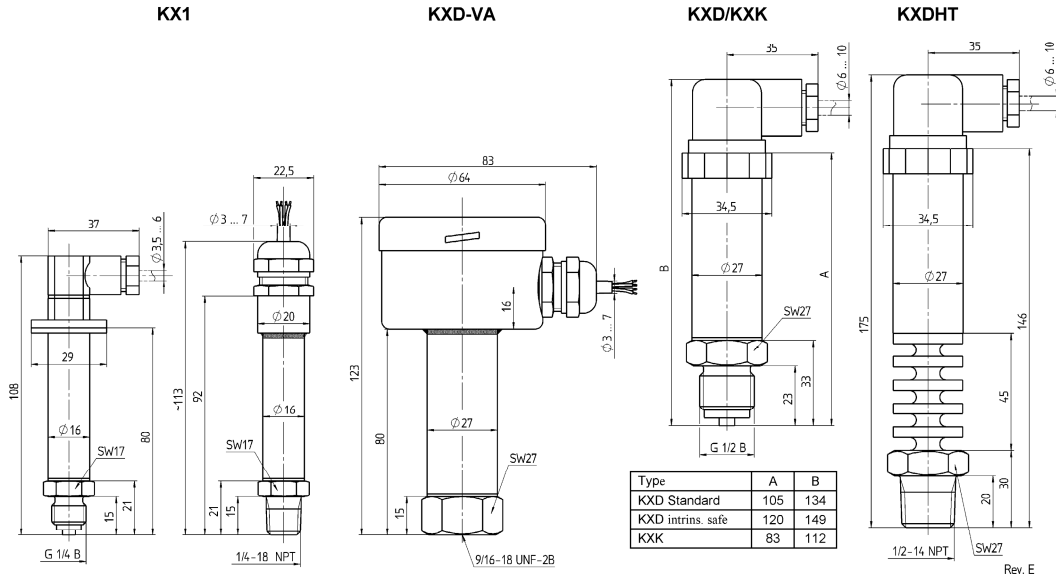

Electrical connection

2-wire

3-wire

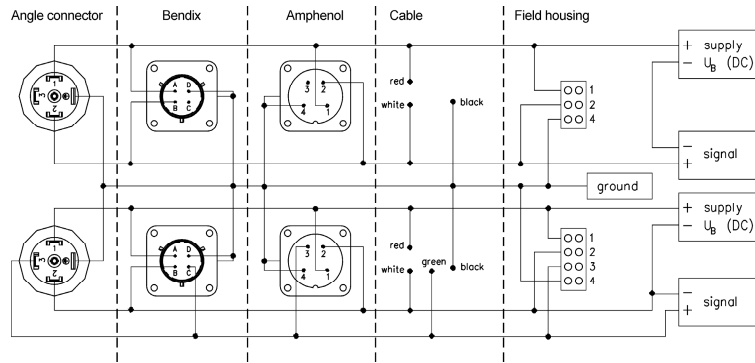

Order information

Type	Output signal	Accuracy	Range	Engineering units	Protection	Process connection	Electrical connection	Options
X1	(42) 4/20 mA	(025) 0,25 % ¹⁾	-1/ 0 ²⁾	BAR	(=) IP65	(MG2)* G 1/4 B male ¹⁾	(HM) Angle connector series M	(NH) Tagging wired
		(050) 0,50 %	-1/ 1,5 ²⁾					
		(100) 1,0 %	-1/ 3 ¹⁾ 5 ¹⁾					
XK	(01) 0/10 VDC		0/ 1 ²⁾ 0/ 1,6 ²⁾ 0/ 2,5 ²⁾ 0/ 4 0/ 6 0/ 10 0/ 16 0/ 25 0/ 60 0/ 100 0/ 160 0/ 250 0/ 400 0/ 600 ²⁾ 0/ 1000 ²⁾ 0/ 1400 ²⁾		(=) IP65	(M02)* 1/4 NPT male ¹⁾	(M1) Angle connector according DIN EN 175301-803	(6B) Oxygen cleaned (HD1) Optional overpressure
XD	(05) 0/5 VDC			(ATEXGD) Intrinsically safe for gas and dust (only for type XD with output signal 4/20 mA and electrical connection F2)	(F09) 9/16-18 UNF-2B Aminco (high pressure)			
XDHT	(15) 1/5 VDC (16) 1/6 VDC (20) 0/20 mA (42) 4/20 mA				(ATEXG) Intrinsically safe for gas (only for type XD with output signal 4/20 mA)	(M04) 1/2 NPT male ¹⁾	(F2) Cable connection	
					(IP68) IP68 (only with cable connection)	others on request	(VA) Field housing in stainless steel (not for KXD (Exi))	
							Specify cable lengths in [m]	
		¹⁾ not for KXX	¹⁾ min. 0,5 % ²⁾ see front page	psi and others on request		* standard connection for KX1 ¹⁾ max. 1000 bar		

How to order

Series	Type	Output signal	Accuracy	Range	Engineering units	Protection	Process connection	Electrical connection	Option
K	X1	42	050	0/10	BAR	=	MG2	HM	NH

Ashcroft Instruments GmbH

Germany
Max-Planck-Str. 1, D-52499 Baesweiler
P.O. Box 11 20, D-52490 Baesweiler
Tel.: +49 (0) 2401 808-0, Fax: +49 (0) 2401 808-125

France
„206“ ZA Le Mandinet Rue des Campanules
F-77185 Lognes
Tel.: +33 (0) 1 60 37 25 30, Fax: +33 (0) 1 60 37 25 39

Website: www.ashcrofteurope.com

e-Mail: sales@ashcrofteurope.com

United Kingdom

Unit 5 William James House
Cowley Road, Cambridge CB4 0WX
Tel.: +44 (0) 12 23 39 55 00, Fax: +44 (0) 12 23 39 55 01